



Technical Bulletin #6

NATIONAL SLATE ASSOCIATION

Technical Bulletin No. 6: Dutch Lap Slate Roofing

Introduction

The Dutch Lap method of installing slate can be defined as a lightweight method in which the slates are laid with a side lap and single lap at the heads of the slates. It differs from the traditional method of installing slate in that a) there is no headlap, and b) the side edges of the slate overlap rather than abut each other (Figure 1). The slates in a Dutch Lap roof can be rectangles, with the long dimension oriented horizontally or vertically, or rectangles with clipped corners for added decorative effect. For example, on a c.1875 mansion in the Spring Garden section of Philadelphia, PA, 16" x 8" shingles were laid with the long dimension oriented horizontally and with a 4" side lap and 2" to 2¾" top lap, thereby providing an exposure of 12" x 5¼" to 6".

In addition to requiring less slate than a traditional slate

roof (each piece of slate can be smaller and still provide for the same exposure), another significant advantage of the Dutch Lap method is its ability to more easily accommodate the curve of a convex mansard roof. For this reason, the Dutch Lap is most often seen on convex-shaped mansard roofs and domes. A smattering of examples can be found in the Mid-Atlantic, New England, and in older cities such as New Orleans. These include the Pine Building entrance of the Pennsylvania Hospital on South 8th Street in Philadel-

Figure 1: Headlap is the amount by which the head of slate in a given course is lapped by the butt of the slate two courses above and is the key to keeping a traditional slate roof weathertight. Side lap is what allows the Dutch Lap method to have only a single lap at the heads of the slates.

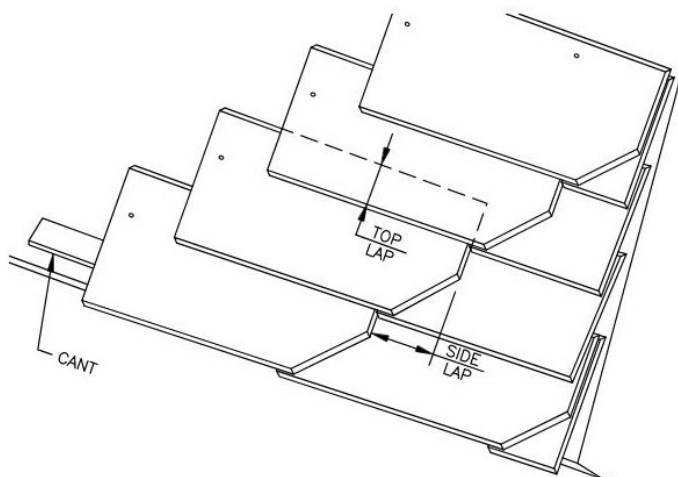

DUTCH LAP SLATE LAYOUT

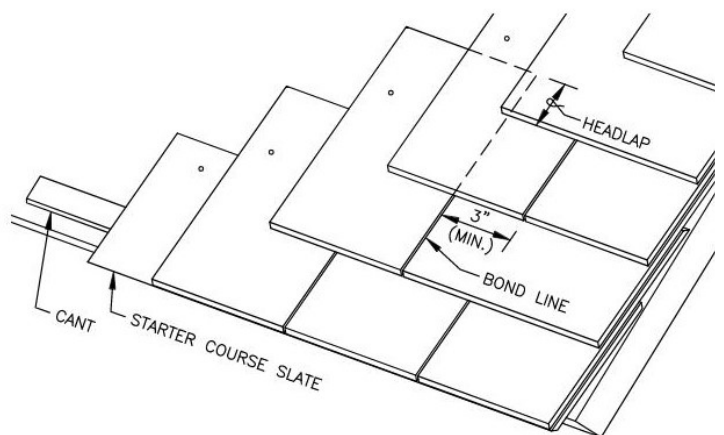

TRADITIONAL SLATE LAYOUT



JANUARY 2019



Figure 2: Dutch Lap slate roofing on the Pine Building entrance of the Pennsylvania Hospital, Philadelphia, Pennsylvania.



Figure 3: Dutch Lap slate roofing on the dome of the center wing of Main Hall, Vassar College, Poughkeepsie, New York, built c.1864.

phia (Figure 2); the American Brewery, Baltimore, Maryland; Third Church of Christ Scientist, New York, New York; and, a particularly spectacular example at Vassar College's Main Building, Poughkeepsie, New York (Figure 3). Importantly, these roofs are also typically rather steep, meaning they are able to shed rainwater quickly and are highly visible from grade, readily showing off their aesthetic qualities. The Dutch Lap method is not appropriate for roofs of moderate slope, due primarily to the threat of moisture infiltration.

Technical information on the design and installation of Dutch Lap slate roofs is quite sparse. *Slate Roofs*, published in 1926 by the National Slate Association, contains a nice graphic, but only states the following with regard to the Dutch Lap method: "Laid with regular slate on shingle lath or tight sheathing."¹ The graphic was often repeated in later

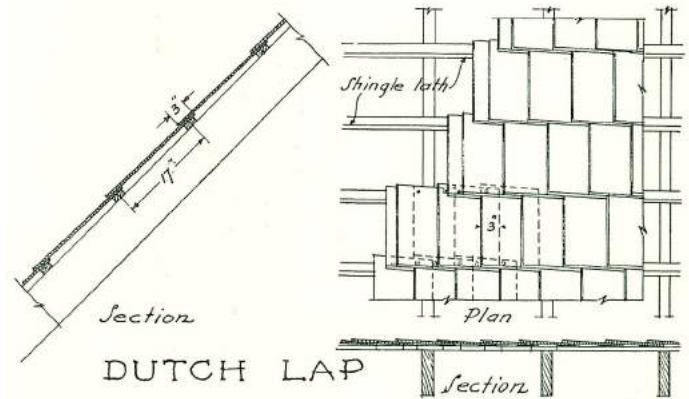

Figure 4: Detail drawing of the Dutch Lap method as shown in the first edition of *Architectural Graphic Standards*.

architectural reference manuals, such as the first and third editions of Ramsey and Sleeper's *Architectural Graphic Standards*, published in 1932 and 1941, respectively (Figure 4).²

Bennett and Pinion, in 1948, make no mention of the Dutch Lap using slate, but do devote a whole chapter to "Single-Lap Tiling." Although discussing clay tile, the concepts would be similar for slate. Bennett and Pinion's words elaborate on the description previously given:

The method of head lapping is, in principle, the same both for single-lap and plain tiling [slab tiles laid in the traditional manner with headlap], but the single-lap tiles lap at the sides as well as at the heads. In plain tiling, while the general thickness is two tiles, at the head lap it is three tiles; but in single-lap tiling, while the general thickness is one tile, at the head lap it is two thicknesses.

*Plain tiles give lateral bond, while single-lap tiles, such as Italian, Roman, and common Pantiles, give side lap instead of bond. If plain tiles were laid in one thickness, that is, without lateral bond, they would be like a sheet covering, slotted with holes. Water would immediately find its way through the vertical joints and sink into the roof. The same would happen with single-lap tiles were it not for the side laps. Even with the side lap water would not be entirely kept out were it not for the curved shape (or other device) which causes water to flow down the middle of the tiles and keep away from the sides.*³



JANUARY 2019

That last sentence is interesting, given that all slate shingles are rather planar. How then, does the Dutch Lap keep rain water out? Recently completed water testing of mock-ups installed on a convex mansard roof by NSA firm member Levine & Company, Inc. suggest that, in a steady rain with no wind, slates laid in the Dutch Lap pattern with a 4" side lap and 3" top lap will shed water with little, if any, moisture penetrating below the slate shingles. In a heavy rain or rain with driving winds, however, some water will penetrate below the slates (Figure 5).⁴

The purpose of this Technical Bulletin is to provide guidance on the key detailing features of Dutch Lap slate roofs and, thereby, hopefully fill-in some of the gaps in the technical literature on the subject. In addition to the issue concerning the weathertightness of the Dutch Lap, information will be provided on whether a starter course is needed,



Figure 5: Water testing was carried out using a garden hose. Water was systematically sprayed at various angles (downward, straight on, at a slight side angle [i.e., into the side laps], and at an upward angle) for durations of three to five minutes. After each interval, slates were removed. When water was sprayed at a downward angle, the rosin paper was found to be dry. Some water did extend into the side and top laps of the slate, but not enough to reach the nail holes. When water was sprayed straight on and at side and upward angles (simulating wind-blown rains), areas of wetness on the underlying rosin paper were observed, and a significant portion of the concealed areas of the slates were wet, including areas around many of the nail heads (see image above)

where the slating nails should be placed, and the amount of lap required.

Underlayment and Substrates

Given the tendency of the Dutch Lap method of slating to allow rainwater to pass during wind-driven rain events, a traditional underlayment consisting of a double layer of #30 felt is not likely to provide a viable system for the long-term. Other options will depend on the particular circumstances – use of the building, ventilation and insulation requirements, base flashing heights, roof slope, etc. – and may include the following:

- **Wood Battens:** Pressure-treated wood battens, or a properly detailed batten and counter-batten system, with a continuous waterproof membrane laid directly on the wood roof deck, or draped between battens, to create a secondary drainage plane and capture any stray moisture that may make its way through the Dutch Lap slate shingles. Keep in mind, a wood batten system will add weight and raise the plane of the roof from $\frac{3}{4}$ " to $1\frac{1}{2}$ ".

- **Ice Dam Protection Membrane Underlayment:** Self-adhering ice dam protection membrane will seal around the slating nails and minimize the potential for water passing through the Dutch Lap shingles to reach the wood roof deck over time. While easy and cost effective, it must be recognized that ice dam protection membrane is an effective vapor retarder/barrier. If placed below the slate over the entire roof deck, warm, moist air from inside the building could potentially condense on the underside of the roof deck during the winter and transitional months.⁵

If in doubt, seek the advice of a design professional knowledgeable on the subject, or reject this option in favor of a breathable underlayment (see below).

- **A Robust Breathable Underlayment:** A highly breathable (permeable), yet water-repellent, synthetic underlayment that can withstand repeated wet/dry cycling and still retain a service life equal to that of the slate shingles will effectively shed stray rainwater making its way past the Dutch Lap shingles. Some such underlayments have very high perm ratings (well over 100 perms per ASTM E96, Procedure B, Water Method) and are supported by special tape accessories that can be used to a) seal the heads of the cap nails employed to secure



JANUARY 2019



Figure 6: Just prior to the installation of each slate shingle, a 4” x 4” piece of self-adhering tape (see arrow) can be placed on the underlayment at each slating nail location to help seal around the nail holes.

the underlayment to the roof deck, and b) seal around the slating nails (Figure 6).

Starter Course and Cant

In a traditional slate roof, both a starter course and cant are needed (see Figure 1). The starter course ensures that rainwater passing over the bond lines in the first course does not penetrate to the roof deck and provides the necessary headlap. The cant lifts the butt end of the starter and first course up off the roof deck a sufficient amount such that the second and succeeding courses of slate lie atop each other in close contact and without their butt ends sticking up. Similarly, a Dutch Lap slate roof needs a cant in order to “get the slates to lay,” but does not necessarily need a starter course. Where sufficient waterproofing will be present below the first course of slate – in the form of a gutter liner or impermeable membrane, for example – a synthetic wood cant hung from copper wires can be used as a cant (Figure 7). In other situations, where the roof underlayment might not be as robust, or the eave is highly visible from grade, a narrow slate measuring roughly half the length of the field slate can be used as a combination cant and starter course (Figure 8).

Nailing

As with a traditional slate roof, each slate in a Dutch Lap slate roof should be secured with two copper slating nails.

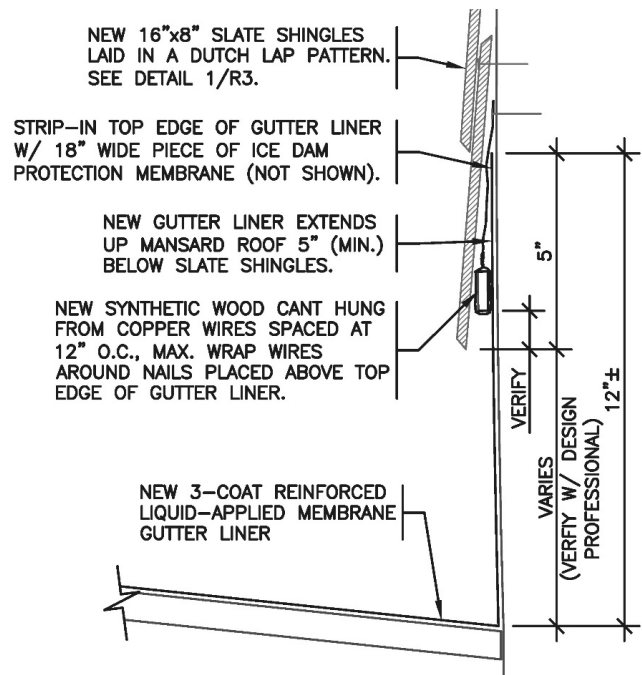

Figure 7: Section showing cant and first course of slate above a built-in gutter.

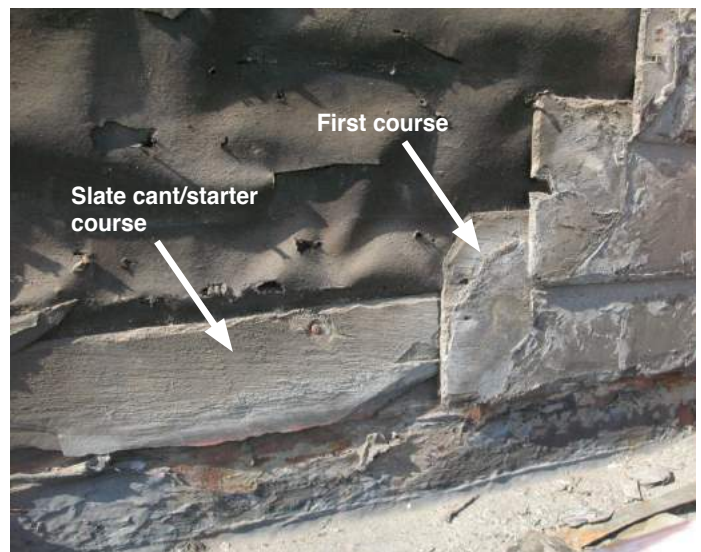

Figure 8: Example of a combination cant and starter slate at the eave of a 142-year old roof.

Nail locations in a Dutch Lap shingle will be covered by the top and side laps of the slates and should be positioned as follows: 1 nail approximately 7/8” down from the top edge of the slate and in from the leading edge of the slate a dis-



JANUARY 2019

ADJACENT TO CHIMNEYS AND DORMER CHEEK WALLS, PLACE SECOND NAIL HERE TO AVOID NAILING THROUGH BASE FLASHINGS.

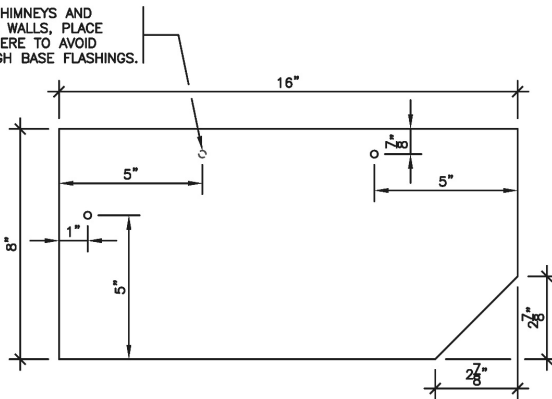

NEW SLATE SHINGLE PROFILE (TYP.)

N.T.S.

Figure 9: Sketch of nail locations for a 16" x 8" slate shingle to be used in a Dutch Lap pattern.

tance equal to one-third the width of the slate minus $\frac{1}{2}$ " +/- (for example, for a 16" wide slate: $16"/3 - \frac{1}{2}" \approx 5"$). The second nail is positioned 1" in from the trailing end of the slate and a distance up from the bottom edge of the slate equal to the exposure. Where slates overlap base flashings, as at chimneys and vertical walls, the second nail location at the side of the slate cannot be used. Instead, to avoid puncturing the underlying flashings, a second nail should be added along the top edge of the slate (Figure 9).

Laps

As a rule of thumb, a 3" top lap and 4" side lap are about right for Dutch Lap slate laid on a very steep roof, such as a mansard (see Figure 1). Another method for deriving an appropriate side lap is to make it equal to from one-fourth to one-third the width (horizontal dimension) of the installed slate. For lower sloped roofs, Dutch Lap is probably not appropriate due to the frequency with which rainwater will pass through the joints in the slate during rain events. If, for historic preservation reasons, a Dutch Lap is desired on a lower sloped roof, increasing the top and side laps would be prudent, if the curvature of the roof will allow. When adjusting the exposure of the slates to accommodate the curve of a mansard or to ensure the correct exposure of the finishing course of slate, adjustments should always be made so as to decrease the exposure and increase the top lap. It should be expected that trial-and-error mock-ups will be necessary to get the layout just

right and ensure the butt ends of the slate will not stick up in any given course.

Slate Direction

The slates in a Dutch Lap roof are directional due to the side laps. Right-handed slates appear to point to the right and are installed from right to left (Figure 10). Left-handed slates appear to point to the left and are installed from left to right. Slate direction is an aesthetic consideration,



Figure 10: View of right-handed, Dutch Lap slates.

but may also depend on the direction of prevailing winds. Once a direction is selected, it must be continued on any given slope until a natural stopping point, such as a hip or vertical wall, is reached. This general rule can be bent a bit, as can be seen in Figure 2, where the direction was changed at the mid-point of the roof, directly above the ocular window.

Slate Order

Slate shingles are typically ordered by the square based on a 3" headlap. Since there is no headlap in a Dutch Lap roof, slate shingles are more appropriately ordered by the piece. The number of pieces can be calculated by dividing the total roof area to be covered by the slate by the exposed area of each shingle or, as in the case of an existing building, by counting the number of existing slates and making any adjustments that may be needed (for example, to account for the reduced exposure of the slates in a new roof compared to that of the existing roof).⁶ Slates will likely be ordered unpunched as quarries are not typically set up to punch the nail holes where needed in a Dutch Lap slate. Nail holes will, thus, have to be punched, or drilled, on the jobsite using a template to help ensure consistency.



JANUARY 2019

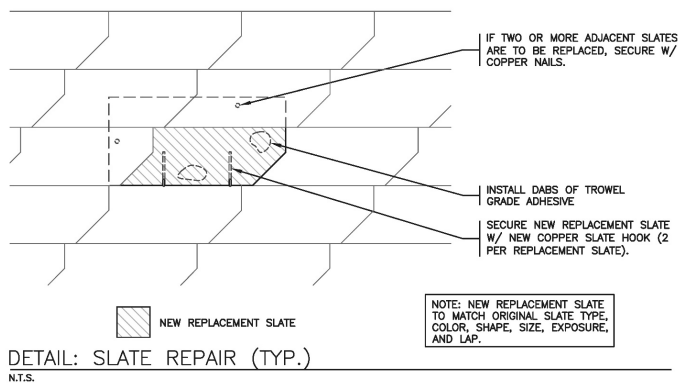

trowel grade adhesive or sealant adhesive (to help prevent wind chatter) can be used to form an effective repair (Figure 13).

Summary

The Dutch Lap slating method provides an aesthetically pleasing roof that can more readily accommodate convex roof shapes than a traditionally-laid slate roof. The Dutch Lap is, however, prone to leakage during wind-driven rain events. To overcome this problem, a secondary, or supplemental, water-shedding membrane can be installed below the Dutch Lap shingles. The membrane should have an expected service life commensurate with that of the slate shingles and have some way of providing a watertight seal around the slating nails. In certain cases, the membrane may also be required to have a high perm rating in order to prevent, or mitigate the potential for, condensation on the underside of the roof deck. In addition, a proper cant at the roof eave, nail locations, side lap, exposure, and slate direction are important detailing considerations that must be carefully thought through and specified to help ensure a successful outcome – a 100-year slate roof.

Figure 13: Slate repair in a Dutch Lap roof.

Slate Repair

Repair of broken slates is more difficult in a Dutch Lap roof than a traditional slate roof because there are no true bond lines in which to insert a nail and bib. Therefore, every effort should be made to not damage the shingles during the construction process. If a shingle is broken, however, a pair of slate hooks and a couple of dabs of

Endnotes

- ¹*Slate Roofs*. New York, New York: National Slate Association, 1926, p.70. Reprinted by the National Slate Association; available at www.slateassociation.org.
- ²Charles George Ramsey and Harold Reeve Sleeper. *Architectural Graphic Standards*. New York: John Wiley & Sons, Inc., 1932, p.64. (Facsimile Edition published 1990 by John Wiley & Sons, Inc.)
- ³Frank Bennett and Alfred Pinion. *Roof Slating and Tiling*. Dorset, England: Donhead Publishing, 2000, p.121. (Reprint of the 1948 second edition published by Caxton Publishing Company Ltd., London. The first edition dated to 1935.)
- ⁴In 2003, Jenkins weighed-in on the Dutch Lap method, together with the Open Slating and French methods (as these methods also reduce the amount of slate required, compared to the traditional method), stating “These styles tend to be found on barns and outbuildings where the owner probably didn’t want to spend extra money on materials. ...Also, these alternative slating methods leave much of the roof covered by only a single layer of slate – a situation more vulnerable to such threats as hail damage.” Source: Joseph Jenkins. *The Slate Roof Bible*. Second Ed. Grove City, Pennsylvania: Jenkins Publishing, 2003, p.149.
- ⁵For example, in a northern climate, if insulation is located on the attic floor, there is no vapor retarder/barrier on the warm side of the insulation, and attic ventilation is limited.
- ⁶To count the number of existing slates on an existing roof, the number of slates in a given course can be multiplied by the number of like courses to speed up the counting process.

For more information on slate roofing, please see *Slate Roofs: Design and Installation Manual*, 2010 Edition, available at www.slateassociation.org



For more information about The National Slate Association, visit www.slateassociation.org

© Copyright: 2019, National Slate Association

Installation Standards Committee: Jeff Levine (Editor), Alan Buohl, Remo Capolino, Dan Cornwell, Dave Large, Russel Watsky.

Published by the National Slate Association

